

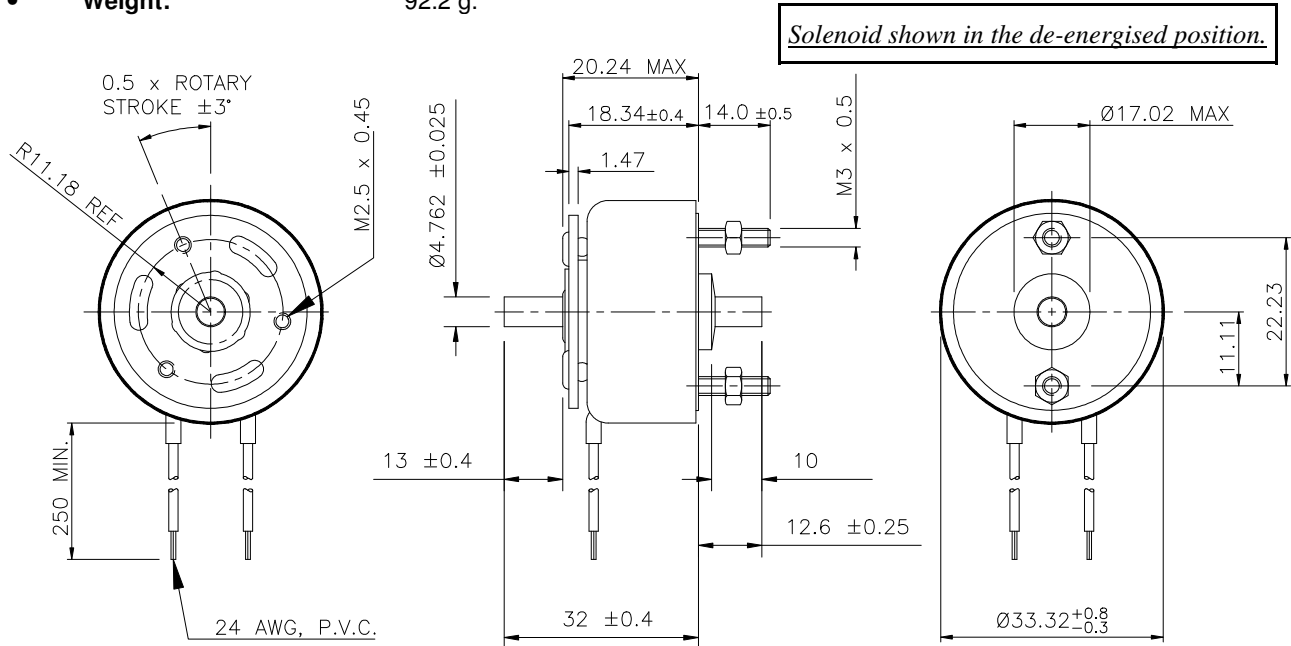

General Specifications:

- **Dielectric Strength:** 23-27awg. 1000 VRMS / 28-33 awg. 1200VRMS
- **Recommended Heat Sink:** Maximum watts dissipated by the solenoid are based on an unrestricted flow of air at 20° C mounted on the equivalent of an aluminium plate 117.5x117.5x3.2mm min.
- **Coil Resistance:** +/- 5% tolerance
- **Starting Torque:** Gross torque values are shown. For net starting torque, subtract return spring torque.
- **Return Spring Torque:** 13.6 mNm +/- 20%.
- **Weight:** 92.2 g.



Performance Specification						
		Starting Torque (mNm) @ 20° C (5)				
		100%	50%	25%	10%	5%
Maximum Duty Cycle		100%	50%	25%	10%	5%
Stroke	Holding Torque (6)					
25°	101.7	39.55	90.4	158.2	305.1	361.6
35°	79.1	29.38	67.8	113.0	226.0	259.9
45°	67.8	16.95	45.2	90.4	158.2	203.4
67.5°	56.5	11.3	22.6	45.2	79.1	101.7

Notes:

- 1 Continuously pulsed at stated watts and duty cycle.
- 2 Single pulsed at stated watts (with coil at ambient room temperature 20° C).
- 3 Other coil gauges available, consult factory.
- 4 Reference number of turns.
- 5 Gross starting torques are shown. For net starting torque, subtract return spring torque of 13.6mNm +/-20%.
- 6 Holding torque is shown at the stabilised temperature of 105° C, 100% duty cycle.

How to Order - Please specify:

- Direction and angle of rotation.
- Coil awg, or voltage and duty cycle
- Supplementary 'X' features ie method of load take off.
- Operating temperature range
- Any special features, if complex please submit a drawing of your requirements.

Coil Specifications							
Maximum Duty Cycle	100%	50%	25%	10%	5%		
Maximum ON Time (sec) When pulsed continuously (1)		100	36	8	2.8		
Maximum ON Time (sec) for single pulse (2)		162	44	9	3.2		
Watts (@20° C)	9	18	36	90	180		
Ampere Turns (@ 20° C)	535	756	1070	1690	2397		
Coil Data							
awg.(3)	Resistance (@ 20°C)	# Turns (4)	Nominal DC Voltage				
23	0.70	145	2.6	3.7	5.2	8.2	11.6
24	1.18	192	3.3	4.6	6.6	10.4	14.7
25	1.97	252	4.2	5.9	8.4	13.2	18.7
26	3.26	328	5.3	7.5	10.6	16.8	24.0
27	5.04	405	6.7	9.4	13.3	21.0	30.0
28	8.02	510	8.4	11.9	16.8	27.0	38.0
29	12.21	627	10.4	14.7	21.0	33.0	47.0
30	19.20	780	13.2	18.6	26.0	42.0	59.0
31	31.84	1008	16.9	24.0	34.0	53.0	76.0
32	46.97	1215	21.0	29.0	41.0	65.0	93.0
33	75.30	1530	26.0	37.0	53.0	83.0	118.0