

SDK-0730L

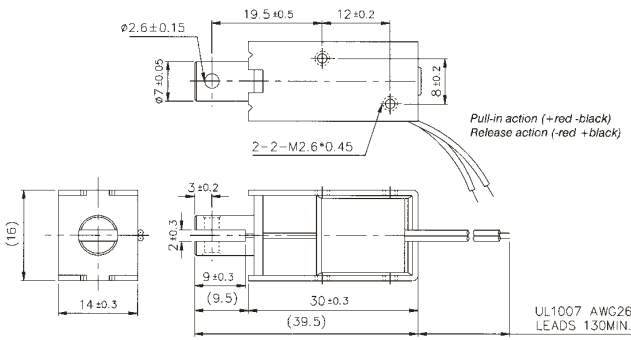

Solenoid Weight 34g – Plunger Weight 8g

STROKE Vs FORCE

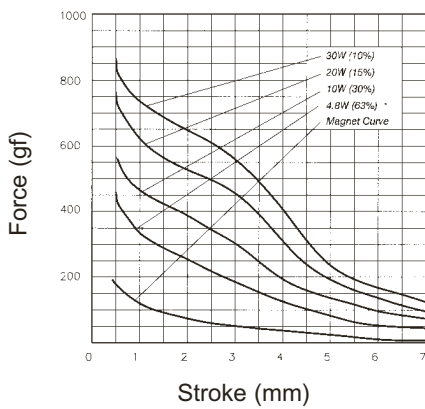

AMPERE-TURNS Vs FORCE

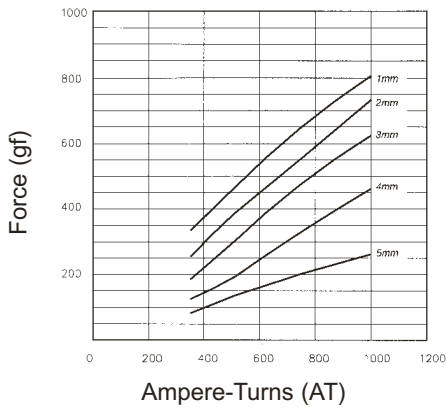

Maximum Duty Cycle (%)	63%	30%	15%	10%		
MAX. "on" time in seconds		60	30	10	8	
Watts at 20°C		4.8	10	40	30	
Ampere-turns at 20°C		350	510	710	880	
Type no.	Resistance (20°C) $\Omega \pm 10\%$	No. turns	Volts DC			
SDK-0730L4.8—	7.5	490	6	8.7	12.2	15
SDK-0730L9.5—	30	916	12	17.4	24.5	30
SDK-0730L19—	120	1700	24	34.8	49	60
SDK-0730L38—	480	3320	48	69.6	98	120

SDK-0730S

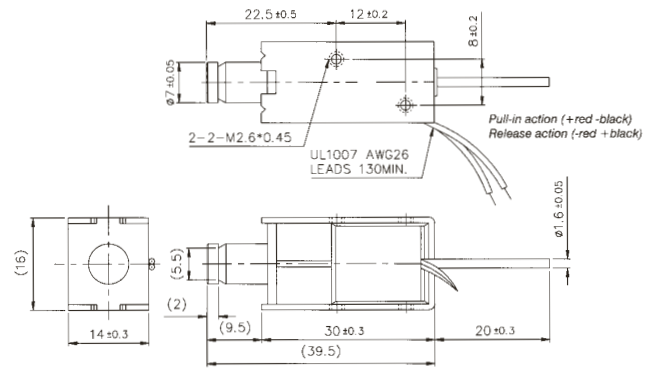

Solenoid Weight 34g – Plunger Weight 8g

STROKE Vs FORCE

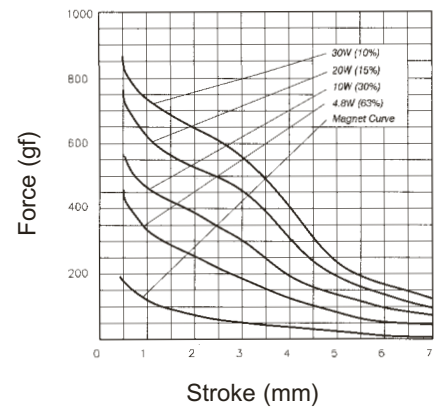

AMPERE-TURNS Vs FORCE

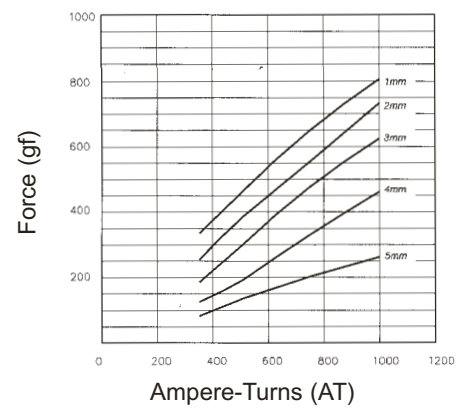

Maximum Duty Cycle (%)	63%	30%	15%	10%		
MAX. "on" time in seconds	60	30	10	8		
Watts at 20°C	4.8	10	40	30		
Ampere-turns at 20°C	350	510	710	880		
Type no.	Resistance (20°C) $\Omega \pm 10\%$	No. turns	Volts DC			
SDK-0730S4.8—	7.5	490	6	8.7	12.2	15
SDK-0730S9.5—	30	916	12	17.4	24.5	30
SDK-0730S19—	120	1700	24	34.8	49	60
SDK-0730S38—	480	3320	48	69.6	98	120